

# PEQUEEN TURF

**SuperSpread**™

**VSS VERSA-SPREAD**  
SYSTEM

## Operator's Manual

**PTO • Tractor Hydraulics • On Board Hydraulics**



Contained in this manual is information that concerns the operation, adjustment and maintenance of Pequea SuperSpreaders. Proper care and operation will assure you of a machine that will be as dependable as you expect it to be. For many years of long service and performance, please have all operators read this manual carefully and keep it available for ready reference.

The Pequea dealer from whom you purchased this spreader will instruct you in its general operation. Your dealer's staff of factory-trained service technicians will be glad to answer any questions that may arise regarding the operation of your spreader.

A complete line of Pequea Machine replacement parts is carried by your dealer. These parts have been inspected at Pequea and are manufactured with the same quality standards as has your spreader, in order to assure you of an accurate fit.

The serial number of this spreader is located on the right front corner of the spreader. When you are writing or calling for information or parts, always refer to this number.



**CAUTION: THIS SYMBOL IS USED THROUGHOUT THIS BOOK WHENEVER PERSONAL SAFETY IS INVOLVED. TAKE TIME TO READ AND FOLLOW THE INSTRUCTIONS. BE CAREFUL!**



**CAUTION: PICTURES IN THIS MANUAL MAY SHOW PROTECTIVE SHIELDING OPEN OR REMOVED TO BETTER ILLUSTRATE A SPECIFIC FEATURE OR AN ADJUSTMENT. REMEMBER TO CLOSE OR REPLACE ALL SHIELDING BEFORE OPERATING THE MACHINE.**

## Improvements and Changes

Because Pequea Machine continually strives to improve all of our products, we reserve the right to make changes and improvements wherever it is practical, without obligation to make those same changes or improvements to the equipment sold previously.

SPECIFICATIONS.....	1
SAFETY DECALS.....	2
CAUTION.....	3
BEFORE USE.....	4
GENERAL INFORMATION.....	5
OPERATION.....	6-11
ADJUSTMENTS.....	12-14
LUBRICATION.....	15-16
MAINTENANCE.....	17-19
TROUBLESHOOTING.....	20-21
MAINTENANCE RECORD.....	22
INDEX.....	23
DELIVERY REPORT.....	24
WARRANTY.....	25

## Specifications

Models	135	195	255
Struck Capacity	1.37 bu.	2.06 bu.	2.75 bu.
Heaped Capacity	1.65 bu.	2.50 bu.	3.30 bu.
Inside Hopper Width	54" to 31"		
Inside Hopper Length	48"	96"	120"
Hopper Depth	36"		
Overall Length w/out Attachment	113"	137"	161"
Overall Width w/Rib Tires	65"		
Overall Width w/Turf Tires	72"		
Loading Height w/Rib Tires	65"		
Loading Height w/Turf Tires	66"		
Box Construction	11 Gauge Galvanized steel with Galvanized bolts		
Chassis	7 Gauge Heavy Duty Welded Construction		
Hub	HD. 6 hole	HD. 8 hole	
Wheel/Tire Size	33/1550 x 16.5 10 ply		33/16LL x 16.1 10 ply
Jack	2k side-wind		
Required Tractor Hp.	20-30 Hp.	25-35 Hp.	30-45 Hp.
Weight with Tractor Hyd. (no attachments)	1250 lbs.	1420 lbs.	1590 lbs.
Spinner Attachment Weight	125 lbs.		
Conveyor Attachment Weight	185 lbs.		
Brush Attachment Weight	50 lbs.		
Beater Attachment Weight	75 lbs.		

**CAUTION**

To Help Prevent Bodily Injury, Entanglement, OR Amputation. Read The Operator's Manual And All Safety Instructions Before Attempting To Operate This Machine.

- Make Certain Everyone Is Clear Of Machine Before Starting Engine Or Operation.
- Stop The Engine, Remove The Key And Wait For All Movement To Stop Before Leaving Operator's Position For Any Reason.
- Keep All Shields In Place. Keep Hands, Feet, Clothing, And Hair Away From Operating Parts.
- Never Adjust, Lubricate, Clean Or Unplug Machine With The Engine Running. See Owners Manual For All Adjustment And Lubrication Procedures.
- Keep Riders Off The Machine.
- Use Slow Moving Vehicle Placard Emblem And Flashing Warning Lights When Operating On Highways Except Where Prohibited By Law.

FAILURE TO HEED THESE WARNING CAN RESULT IN BODILY INJURY OR DEATH

**WARNING**

**Moving Parts. Stay Clear When Machine Is In Operation. Failure To Heed This Warning Can Result In Injury Or Death.**

**DANGER**

FLOOR CHAINS AND SPINNERS CAN ACCIDENTLY START MOVING

**NEVER ALLOW RIDERS ON THIS MACHINE**

PEOPLE WHO FALL OR GET PULLED INTO SPINNERS WILL BE SERIOUSLY INJURED OR KILLED



**CAUTION**

To Help Prevent Bodily Injury, Entanglement, OR Amputation. Read The Operator's Manual And All Safety Instructions Before Attempting To Operate This Machine.

- Make Certain Everyone Is Clear Of Machine Before Starting Engine Or Operation.
- Stop The Engine, Remove The Key And Wait For All Movement To Stop Before Leaving Operator's Position For Any Reason.
- Keep All Shields In Place. Keep Hands, Feet, Clothing, And Hair Away From Operating Parts.
- Never Adjust, Lubricate, Clean Or Unplug Machine With The Engine Running. See Owners Manual For All Adjustment And Lubrication Procedures.
- Keep Riders Off The Machine.
- Use Slow Moving Vehicle Placard Emblem And Flashing Warning Lights When Operating On Highways Except Where Prohibited By Law.

FAILURE TO HEED THESE WARNING CAN RESULT IN BODILY INJURY OR DEATH

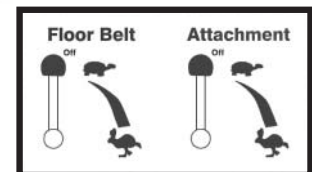



**MOST EQUIPMENT ACCIDENTS CAN BE AVOIDED BY THE OBSERVANCE OF A FEW SIMPLE SAFETY PRECAUTIONS.**

1. Do not clean, lubricate or make any adjustments on the spreader while it is in motion.
2. Do not start the spreader until you know everyone is clear of the machine and have made sure no tools are lying on the machine.
3. Do not work around the unit in loose clothing that might catch in any of the moving parts.
4. Do not attempt to pull material from any part of the spreader while it is in operation.
5. Do not get off the tractor while tractor PTO is engaged.
6. Replace all shields after lubrication or repairs.
7. Do not allow anyone to ride on spreader.
8. Park on level ground or block wheels to prevent spreader from rolling.
9. Always follow manufacturer's instructions for maintenance, repair, or adjustments.
10. Pequea machine Inc., assumes no liability for injuries sustained because of failure to read this manual or from carelessness. Always refer to this manual for guidance or contact your local dealer.
11. Read and pay special attention to hydraulic line safety. See page 7 in this manual.



**NEVER ATTEMPT TO STOP A LEAK BY COVERING IT WITH YOUR HAND, SEVERE INJURY WILL OCCUR.**

# Before Using The New Machine



1. Check for proper assembly and adjustment and make sure all bolts are tightened securely. **RETIGHTEN THE BOLTS AFTER A FEW HOURS OF OPERATION.**
2. Torque the wheel bolts to 120 ft. lbs. Recheck the bolts after every other load until the torque does not decrease and every 300 loads thereafter.
3. Check the tires and inflate them to the recommended pressure shown on the side wall of each tire.
4. Adjust the tractor hitch and attach the spreader to the tractor as detailed in the following sections.
5. Connect the hydraulic hoses to the tractor hydraulic ports if required.
6. Lubricate the machine completely and check the oil level of the hydraulic reservoir. (See the hydraulic section on page 7).
7. Equip the spreader with an SMV (Slow Moving Vehicle) emblem (available from your dealer) if it will be transported on public roadways.
8. Do not operate the spreader until the safety precautions in this manual and on decals on the spreader have been read and understood by the operator.

On Pequea Machine, Inc. equipment, left and right are determined by standing behind the unit, looking in the direction of travel.

**Important:** New belts will stretch most during initial use. Inspect belt for slippage on each use until you are satisfied the drive system belt has attained its maximum stretch during the break in period. Refer to belt adjustment page 19.

## TRACTOR SIZE



**CAUTION: NEVER USE A TRACTOR THAT IS TOO SMALL. WHILE A SMALL TRACTOR MAY BE ABLE TO PULL THE UNIT IT MAY NOT PROVIDE ADEQUATE TRACTION AND BRAKING TO CONTROL THE WEIGHT OF THE LOADED SPREADER ON HILLS AND FOR STEERING.**

A good rule is to use a tractor that is heavier than the spreader and load combined.

## TRACTOR HITCH

The hitch of the spreader is designed for a standardized tractor hitch. Adjust the tractor drawbar so it is 13"-17" above the ground.

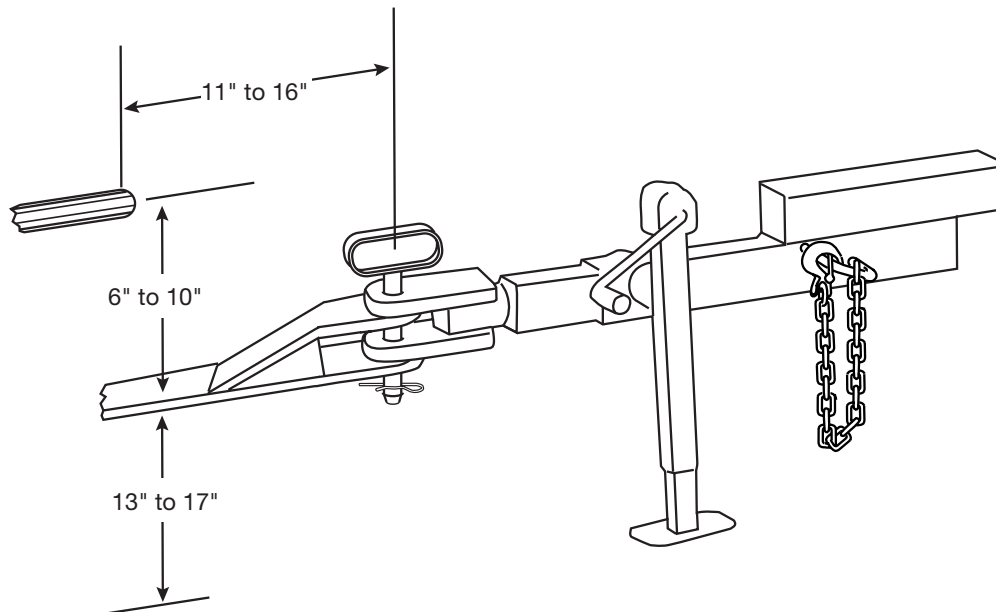

## Attaching to the Tractor

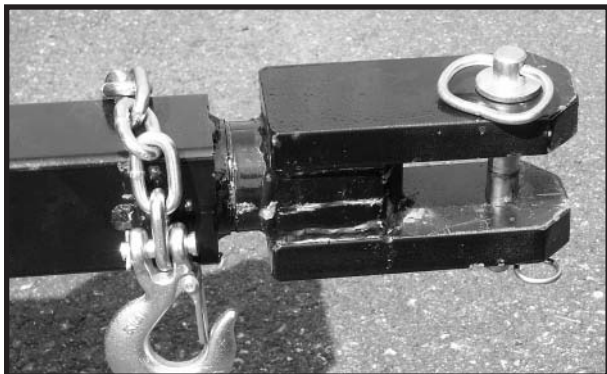

Figure 8-1



Figure 8-2

1. Fasten the spreader hitch to the drawbar with a 1" diameter hitch pin that cannot bounce out, Figure 8-1. Attach hitch safety chains to tractor.



**CAUTION: DAMAGE TO THE SPREADER OR OTHER VEHICLE, AS WELL AS INJURY TO THE OPERATOR, MAY OCCUR IF A CORRECT PIN IS NOT USED.**

PTO Output Spline

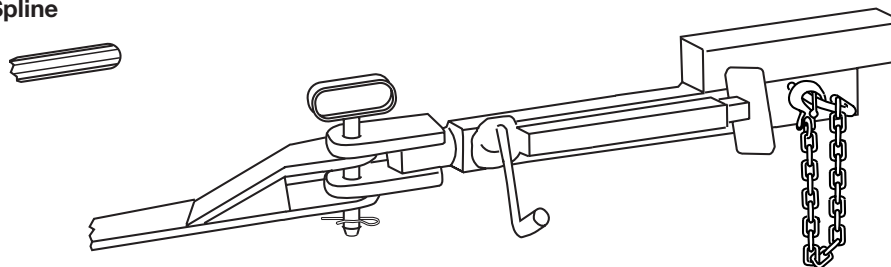

2. Remove the weight from the jack. Swing the jack into a horizontal position and lock it to provide maximum ground clearance.

### PTO Models

Pull back on the collar and slide the PTO onto the tractor shaft until the balls engage in the groove in the tractor shaft. Release the collar, Figure 8-2. Check to make sure that the PTO is locked on the shaft. To remove the PTO, pull back on the collar to unlock the balls and slide the PTO off the tractor shaft.

Attach PTO shield safety chains to spreader and tractor.

**NOTE: The balls and yoke hub where the collar slides must be free of paint and/or rust and must be kept lubricated with oil for proper operation.**

## Attaching Cont.

Attach the hydraulic hoses to the tractor hydraulic outlets. Keep the hydraulics clean. Always clean the hydraulic hose fittings before connecting them to the tractor hydraulic couplings.



**CAUTION: BEFORE DISCONNECTING LINES OR FITTINGS, BE SURE TO RELIEVE ALL PRESSURE. BEFORE APPLYING PRESSURE TO THE SYSTEM, BE SURE ALL CONNECTIONS ARE TIGHT AND THAT ALL LINES, PIPES, AND HOSES ARE NOT DAMAGED.**

**WARNING: FLUID UNDER PRESSURE CAN HAVE SUFFICIENT FORCE TO PENETRATE THE SKIN, CAUSING SERIOUS PERSONAL INJURY. ALWAYS PROTECT THE SKIN AND EYES FROM ESCAPING FLUID UNDER PRESSURE.**

**IF INJURED BY ESCAPING FLUID, OBTAIN MEDICAL ASSISTANCE AT ONCE. SERIOUS INFECTION OR REACTION CAN DEVELOP IF MEDICAL TREATMENT IS NOT ADMINISTERED IMMEDIATELY.**

## Unhitching

Before unhooking the spreader, make sure the PTO, safety chains, and hydraulic hoses are disconnected.



**CAUTION: PARK ON LEVEL GROUND AND BLOCK THE WHEELS TO PREVENT THE SPREADER FROM ROLLING.**

## Loading

Always load with the spreader on a flat surface and hitched to the towing vehicle. Best results are attained by distributing the load from the front to the back.

Never exceed the maximum weight as determined by combining the weight shown on each tire, (i.e. maximum shown on tire times number of tires on spreader, minus weight of spreader equals weight of payload).

***NOTE: Spreader should not be stored outdoors, loaded, without a tarp covering the load. Depending on the material to be spread, the additional weight caused by rain might exceed maximum GVW of spreader.***

***Allowing a loaded spreader to be stored outdoors in freezing weather might cause severe damage to the equipment.***

## Transporting

SuperSpread™ is designed to travel safely at highway speeds, unloaded (empty). Attempting to transport spreaders that are loaded at highway speeds may cause damage to tires, bearings and may impair safe driving. See imprint on the sidewall for allowable highway speed. Never transport equipment on public roads without having safety chains installed and connected correctly to the towing vehicle.

Chain should be of sufficient length to permit full turning radius and crossed when hitched to towing vehicle. See illustration below.

Check connection frequently on long trips.

***NOTE: Transporting the machine with the rear section of the PTO assembly dangling from the jack shaft may damage this part. The shield will be dented as a result of bouncing against the hitch, by the drawbar or bumper when left dangling, and dirt and grit from the road will accumulate on the critical internal sliding surfaces. Remove the complete PTO assembly when towing the spreader with a truck.***

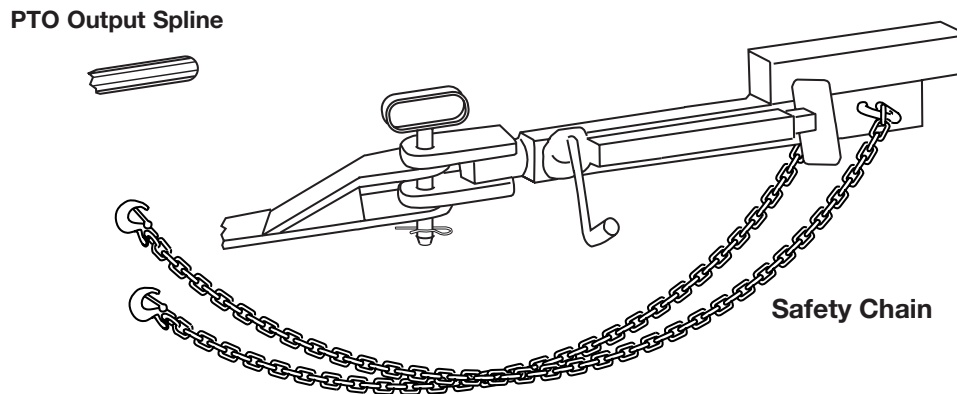

## Operation Overview

### Drive Styles

- PTO- PTO models require a towing vehicle engine speed that affords 540 rpm at the power take off.
- Towing Vehicle Hydraulics- Oil flow must be maintained at 7 to 8 gal. per minute. (adjust engine speed accordingly). Typically, setting the tractor engine speed to between 1600 and 1800 rpm will provide the proper volumes.

**NOTE:** Because tractor hydraulic pumps differ, you must refer to your manual.

- On Board Hydraulics- Maintain engine speed at highest rpm. Engine throttle is preset at factory to maintain proper pump pressure.

### Ground Speed

Optimum ground speed for effective spreading is approximately 6 mph. This speed will vary according to application rate, material being spread, and weather conditions. Dampness affects the rate at which some materials spread. Vary speed accordingly from 2 to 8 mph.

**NOTE:** Maintain PTO speed at 540 rpm. Using the tractor tachometer, select a gear that provides the required PTO rpm and desirable ground speed.



**CAUTION:** NEVER EXCEED THE SPEED INDICATED ON THE SIDE WALL OF TIRE.

### Spreading

**NOTE:** A number of factors determine how the load is spread. While this manual will attempt to provide basic starting adjustments, the most effective operation will be determined from experience.

- Rear Gate Opening- For most materials begin with the gate open approximately 1 $\frac{1}{2}$ ". Adjust gate to greater or lesser opening to increase or decrease material flow. Gate opening varies from closed to 16".
- Delivery Device Speed- Normal speed of dual spinners creates up to a 35' spread pattern of most material. Reducing the spinner speed causes the spread pattern to be narrower, but with greater depth. Other accessories will respond similarly.
- Belt Speed- Faster belt speeds increase material to delivery devices, thereby increasing distribution. Belt speed varies from 0-30" per minute.

**NOTE:** Some materials tend to bridge across the hopper, impairing flow. An optional beater can be installed near the gate opening (See image 14.2). Call your dealer for more information.

## Spreading



Never stand behind the spreader end gate to make adjustments, perform maintenance or repair when power source is active.



Load spreader hopper according to instructions in this manual (pg. 7). Check to make sure that spreader hydraulic hoses are connected properly (see photos below).

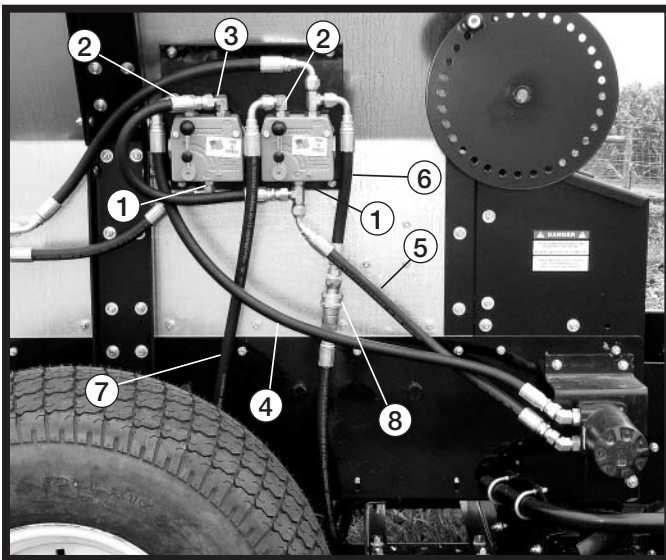

*Without agitator*

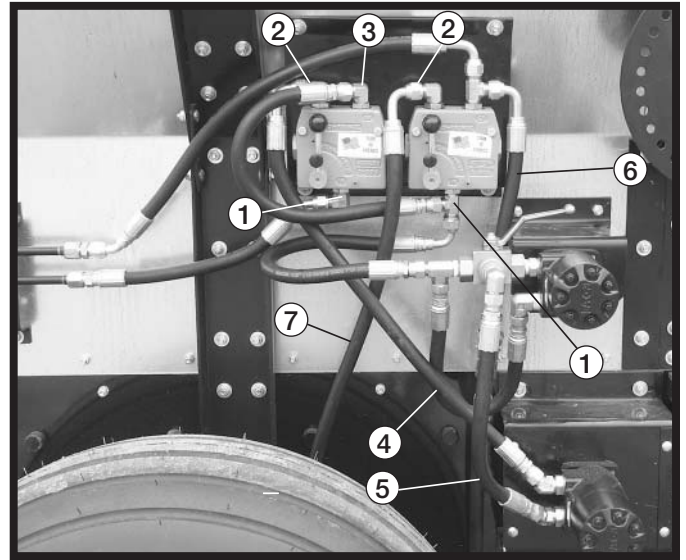

*Model 195 shown with optional ball valve on beater control*

- 1- Flow Control Inlet Ports
- 2- Flow Control Pressure (Drive) Ports
- 3- Flow Control Excess Flow Ports
- 4- "Belt" Drive Hose

- 5- "Belt" Return Hose
- 6- Attachment Return Hose
- 7- Attachment Drive Hose
- 8- Quick Connect Hose Couplers

## Spreading Continued

*With spreader properly hitched to tractor and/or all hydraulic lines correctly attached and PTO attached.*

- PTO Models-
  - 1). Ensure PTO engagement control on tractor is off.
  - 2). Check to confirm that PTO is properly connected to tractor and spreader with safety chains secured.
  - 3). Open end gate to 1<sup>1</sup>/<sub>2</sub>" (see end gate adjustment pg 12).
  - 4). Adjust web speed control (see below) to #6.
  - 5). Adjust spinner speed (see below) to #6.
  - 6). With tractor ground speed at 2 mph, engage PTO control while monitoring spread pattern for 25 ft. If changes are desired in spread pattern (width and depth) disengage PTO engagement control, stop tractor, make appropriate adjustments.
    - Increase opening in end gate for increased depth of "spread".
    - Increase spinner speed to widen spread pattern.
    - Decrease spinner speed to make spread pattern narrower.

**NOTE:** *Web speed may need to be increased or decreased in conjunction with adjusting end gate opening for desired spread depth.*

- 7). Return to tractor, increase ground speed to provide safe comfortable operating conditions (not to exceed 8 mph) and evaluate "spread".
- 8). Follow the preceding steps to make appropriate adjustments until desired spread pattern and depth is attained.

- Tractor Hydraulics-
  - 1). Ensure that tractor hydraulic controls are in the off position. Using the tachometer adjust engine speed to provide hydraulic flow of 7 gpm.
  - 2). Repeat steps 3-8 as described above for PTO models.

**NOTE:** *An excessive flow rate may cause fluid deterioration and damage to the equipment due to overheating.*

- On Board Hydraulics-
  - 1). Ensure that operating controls on the spreader are in the off position.
  - 2.) Following instructions from engine manufacturer, start engine.
  - 3). Adjust spreader engine to safe operating speed. Repeat steps 3-8 as described above in PTO models.

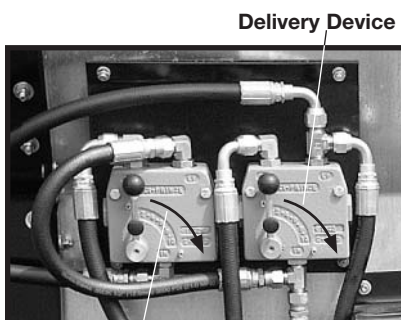

Web Speed Control Position 1

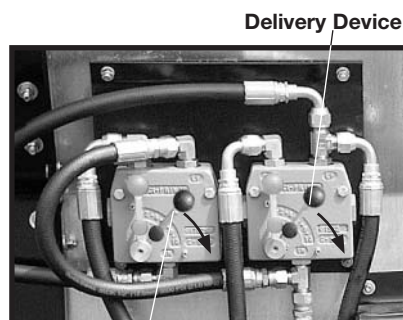

Web Speed Control Position 6

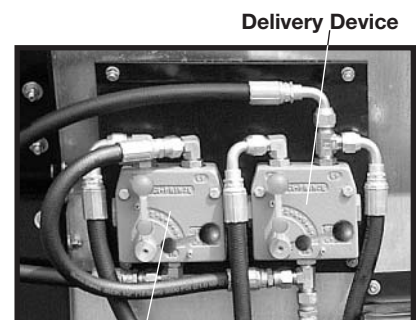

Web Speed Control Position 10

## Spread Adjustments

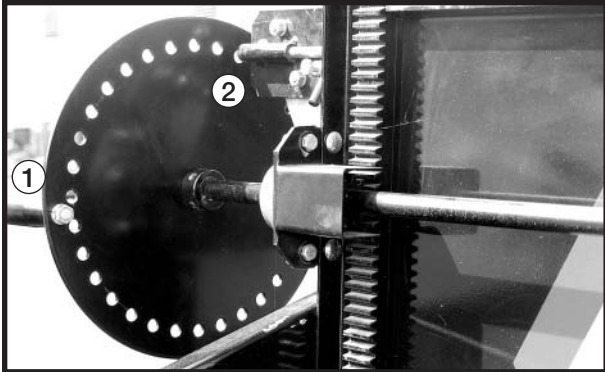

Image 12-1

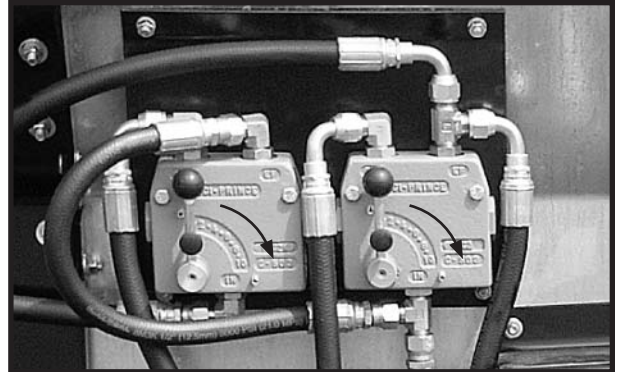

Image 12-2

- **Metering Gate Adjustment**
  - 1). Remove pressure from stop pin by grasping adjustment disc handle (1) and raising gate slightly. (See Image 12-1 above)
  - 2). Slide stop pin (2) to the right removing the pin end from the adjustment disc so that disc moves unimpaired. Turn disc to raise or lower gate. Slide stop pin into the nearest hole on the end gate.
  
- **Web Speed**

Speed increases when control is moved clockwise and decreases when it is moved counter-clockwise. (See Image 12-2 above)

## Attachment Adjustments

All attachment adjustments are made by adjusting the position of the control handle located closest to the rear of the spreader (shown above on right side).

- **Brush**
  - 1). For fine, narrow row spreads the brush attachment can be adjusted by increasing the speed of the brush by turning the controls to the right or decreasing the speed of the brush by turning the control adjustment to the left.
  - 2). Further adjustment can be obtained by moving the brush vertical or horizontal to compensate for brush wear. Bristles should only lightly brush against the belt. Excessive contact will unnecessarily wear bristles and damage the belt.
  
- **Delivery Beater**
  - 1). Adjusting beater speed causes spread width to increase or decrease.
  - 2). Row width increases when control is moved clockwise and decreases when it is moved counter-clockwise.
  - 3). Row width will vary from 5'-12'.
  - 4). Additional adjustment can be made by moving the beater up or down as it is mounted to the spreader. **NOTE: Vertical adjustments up or down require realigning the beater in relation to the belt. Loosen bolts that secure the beater drive motor and move it in or out accordingly. The best position for the beater is  $\frac{5}{16}$ " from the belt, but never less than  $\frac{1}{4}$ ".**

- Conveyor

Row width adjustment on the conveyor attachment is accomplished by loosening the row width gates, this is done by rotating lever A counter clockwise, when facing the rear of the machine. Set tension of lever A so that gates can be positioned conveniently. Lever A is then tightened to secure positioning of row width gates.

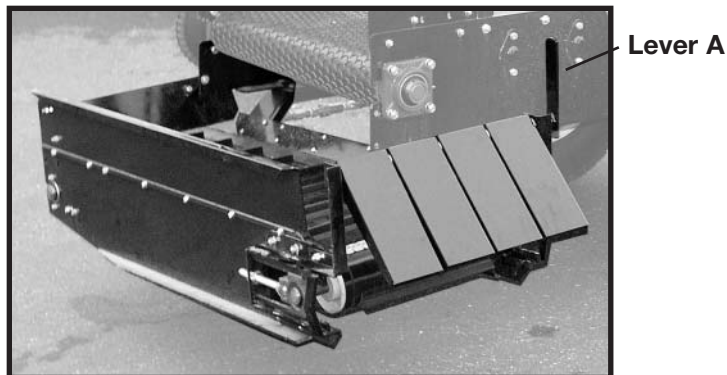

With row width gates all aligned at the 5 o'clock positioning, the resulting row will be approximately one foot wide and at maximum depth. (See drawing #1)

With row width gates aligned from the 5 o'clock position gradually opening to the 3:30 position, row width will be approximately 3' wide, but less concentrated. (See drawing #2)

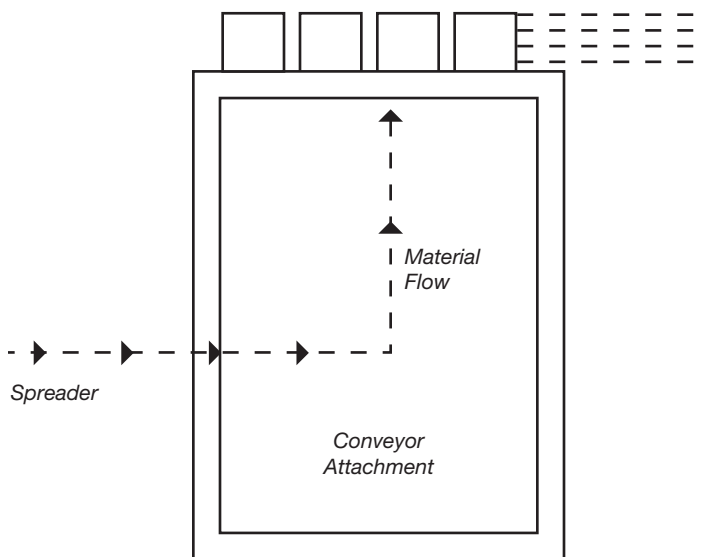

Drawing #1

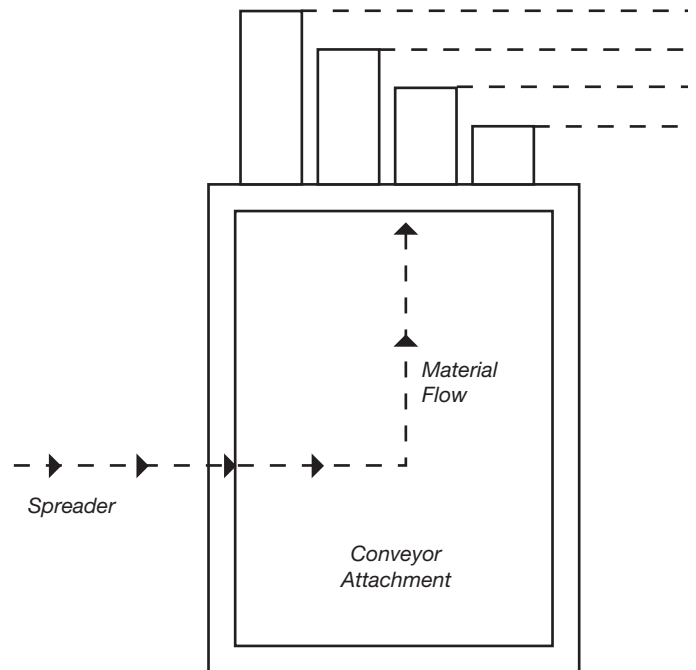

Drawing #2

**NOTE:** An optional conveyor speed adjustment control can be installed for "in-tractor" convenience.

- Spinners

- 1). Adjusting spinner speed causes spread width to increase or decrease.
- 2). Row width increases when control is moved clockwise and decreases when it is moved counter-clockwise.

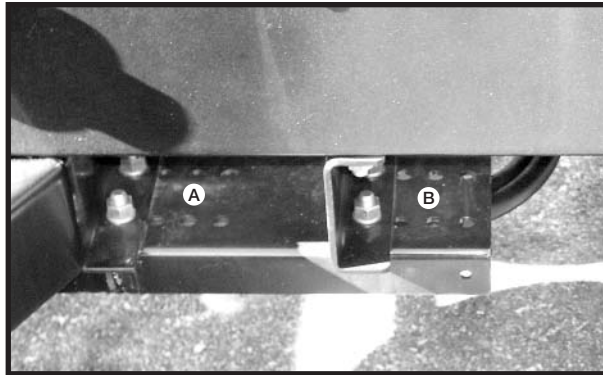

Figure 14-1

### Additional Adjustment

While the spinner attachment is preset at the factory for uniform spread across the width of distribution, adjustment can be made to increase the amount of material to the outer areas of the spread pattern or to the inner areas of the spread pattern. Image 14-1 illustrates 4 adjustments in the spinner mounting channel. Moving the spinners toward the back of the spreader will increase the material in the inner area of the spread pattern, and moving the spinner forward increases the amount of material in the outer area of the spread pattern.

Support spinner assembly channel on left and right of machine and remove bolts at "A" and "B" on both sides. Move channel forward or back to make appropriate adjustment. Replace bolts at "A" and "B" and tighten fully.

## Optional Agitator Beater

Some materials tend to bridge across the hopper impairing flow. An optional top beater can be installed near the gate opening. Call your dealer for more information.

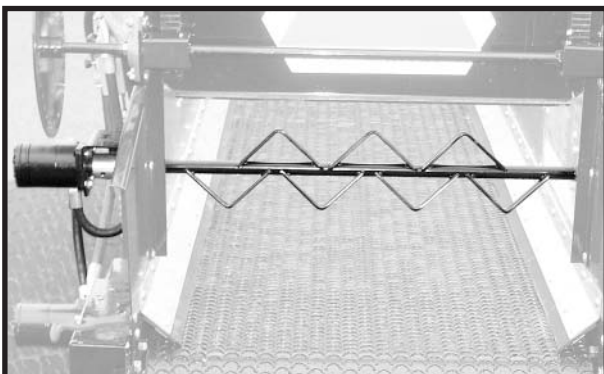

Figure 14-2



Figure 15-1

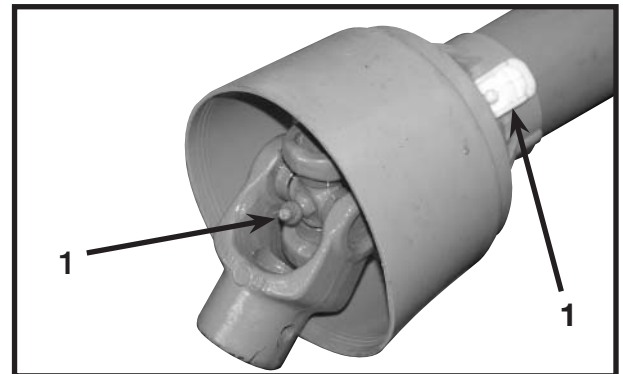

Figure 15-2



**CAUTION: ALWAYS STOP THE MACHINE TO LUBRICATE OR TO MAKE ANY ADJUSTMENTS.**

The SuperSpread is designed to require a minimum of lubrication. However, the importance of sufficient and proper lubrication cannot be over-emphasized as it is the best insurance against unnecessary repairs and will greatly increase the life of the machine.

The operator should become familiar with all lubrication points and establish a systematic routine to ensure complete and quick lubrication of the machine. Refer to the following pages for location of grease fittings.

The following system of lubrication is suggested:

Lubricate the entire machine thoroughly with a good grade of gun grease every 100 loads or once a month, whichever comes first. Make certain the grease fittings are free of paint and dirt and force grease into them until the grease comes out around the shaft. *Caution: Do not over lubricate sealed bearings.* Following a regular maintenance schedule, one stroke of a manual grease pump into a U joint Zerk fitting and a half stroke on any other sealed bearing should be sufficient.

The following greases are recommended for use rather than other EP-2 lubricants, because they are less prone to washing out under exposure to rain and other fluids.

Texaco Marfak Multipurpose #2  
Gulfcrowne #2 (Gulflex A)  
Shell Alvania EP-2

Shell Super Duty  
Exxon Ronex MP  
Lubriplate 1200-2

1. PTO universal joint – (Front) 2 Fittings Figure 15-1\*
2. PTO universal joint – (Rear) 2 Fittings Figure 15-2\*

**NOTE: Use care when greasing universal joints, as seals may be damaged.**

\* These are sealed bearings.

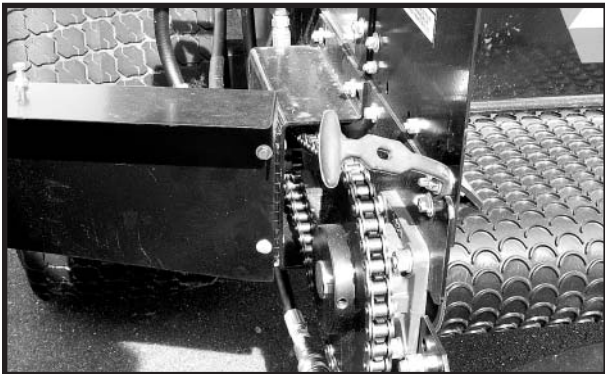

Lubricate the conveyor drive chain with SAE #03 oil or similar lubricant at least twice yearly, more often if the spread material is of high acid nature or if the machine is stored outside. Regular lubrication of the conveyor chain will substantially increase its life.

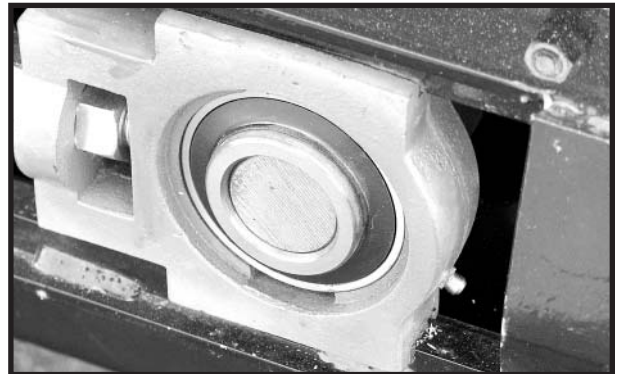

Lubricate all grease fittings (there are 4) according to instructions found on page 15. Fittings require lubrication on each end of the web front roller and on each end of the web rear roller.



**CAUTION: DO NOT ATTEMPT TO CLEAN OR ADJUST THE MACHINE WHILE IT IS RUNNING.**



Figure 16-1

Remove cotter key and turn hub nut counter clockwise. Apply slight pressure on top face of tire to loosen bearing. Remove bearing, clean and pack with new, clean grease. Replace bearing, and tighten nut fully. Do not over tighten.



Figure 16-2

Attempt to spin tire. If it is sluggish, turn nut counter clockwise at least  $\frac{1}{6}$  turn but no more than  $\frac{1}{2}$  turn. Replace cotter key and bend ends. Replace hub cap.

Lubricate wheel hubs every 100 loads. Figures 16-1,2

## General



**CAUTION: REPLACE ALL SHIELDS AFTER ANY MAINTENANCE, REPAIR, OR ADJUSTMENTS. FAILURE TO DO SO COULD RESULT IN SERIOUS PERSONAL INJURY OR DEATH.**

Check to be sure all PTO safety shielding is free turning. The space between the drive shaft and shield should be lubricated to prevent corrosion.

- Remove spread material buildup regularly.
- Protect the machine from the weather when it is not in use.

At the close of the season, check the machine carefully and replace all worn or damaged parts. **USE GENUINE PEQUEA MACHINE, INC. SERVICE PARTS SUPPLIED BY YOUR AUTHORIZED PEQUEA MACHINE, INC. DEALER.**

Keep spinners and conveyor clean. Remove any residue, spread material buildup, and foreign objects from SuperSpread regularly.

- Clean the spreader after each use.
- Check the spreader each time it is used for loose, bent, broken or missing parts. **NOTE: With the machine in operational mode, listen for sounds which might indicate loose parts or other equipment damage.**

**NOTE: Never store material in the spreader during cold weather months when freezing could result in severe equipment damage (i.e. torn floor apron belt). Storing wet material in the spreader (or keeping the spreader outdoors with material in it) will cause premature corrosion. Storing material in the spreader makes the material difficult to unload.**

- **PTO Models**
  - 1). Inspect PTO safety shield and chain regularly to check the condition of the links; replace the shield and chain as soon as weakness/breakage is noted.
  - 2). Inspect the transportation safety chains to check the condition of the links; replace the chains as soon as weakness/breakage is noted.
  - 3). Lube the hydraulic PTO shaft universal joints once a year or every 100 hours.
- **Delivery Beater**
  - 1). Lightly grease the lube fitting on each attachment every 100 hours.

## Wheel/Tire Maintenance

- Once a month check the wheel lug bolt torque. The recommended torque is 120 ft. lbs.

## Hydraulic System Maintenance

- Periodically check the condition of the hydraulic hoses for flexibility and any signs of rubbing/weakness on the outer surface. Replace the hose(s) as soon as any weakness or cracking is noted.
- **Tractor Hydraulic**
  - 1). Inspect PTO safety shield and chain regularly to check the condition of the links; replace the shield and chain as soon as weakness/breakage is noted.
  - 2). Inspect the transportation safety chains to check the condition of the links; replace the chains as soon as weakness/breakage is noted.
  - 3). Lube the hydraulic PTO shaft universal joints once a year or every 100 hours.

## Hydraulic System Maintenance Continued

- PTO Hydraulic

The PTO Hydraulic Model is supplied with either Castrol Blue Hydraulic Oil or Shell Pellus Plus 46 in the reservoir. These are both ISO grease 46. Replace the oil filter after the first 10 hours of operation. After that initial period, replace the filter every 300 hours (in dusty conditions) or every year.

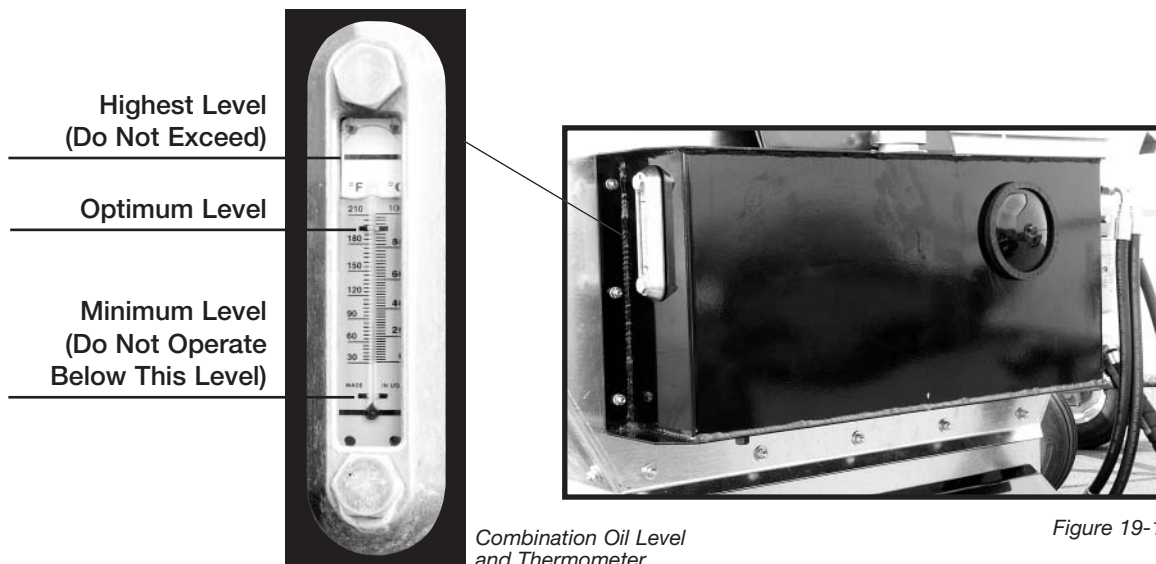

Combination Oil Level and Thermometer

Figure 19-1

**NOTE:** If the filter is clogging too often, or if there is contamination in the fluid, then flush system of used oil. If PTO hydraulic unit is converted to a Tractor Hydraulic unit, be sure to check that the hydraulic oil is compatible with the oil in the tractor. If it is not, the hydraulic system must be flushed out with new oil to ensure proper functioning and to prevent equipment damage.

## Wheel Bearing Maintenance

Adjust wheel hub bearings after 100 loads and once each season thereafter.

Jack up the spreader to remove the weight from the wheel(s). Remove hub cap and cotter pin. Torque wheel hub bearings to 35 ft. lbs. while rotating the hub. Back off/loosen, the nut one flat plus enough to install the cotter pin, (Figure 18-2), 1/6 turn minimum, 1/3 turn maximum.



Figure 18-1

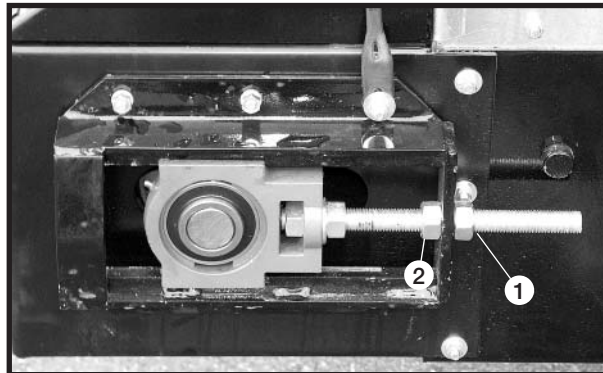

Figure 18-2

## Drive System (Floor Apron Belt) Maintenance

- Periodically check the floor apron belt for proper tension and tracking.
- **Tension**
  - If belt slips, adjust belt roller bearings.
    - 1). Loosen nut (#1) on both sides of the machine.
    - 2). Turn adjustment nut (#2) one full turn at a time on both right and left sides.
    - 3). Run machine for 5 minutes to check for slippage.
    - 4). Tighten until belt no longer slips.
    - 5). Recheck.
- **Belt Tracking**
  - 1). If belt appears to be out of alignment, loosen nut (#1) and adjust nut (#2) accordingly to cause belt to return to proper alignment.
  - 2). Retighten nut (#1) to fix bearing position in place.

**NOTE:** Correct self-alignment of the V-groove track belt is obtained when there is no raised bulge at the center of the belt.



**Model 255**

Figure 19-1

When the conveyor drive chain is properly tensioned (Figure 19-2), it should deflect  $\frac{1}{2}$ " from a straight line mid-way between the sprockets. The chain is tightened by loosening 4 nuts on the drive motor (A, Figure 19-3) and sliding unit to the left. Retighten nuts.

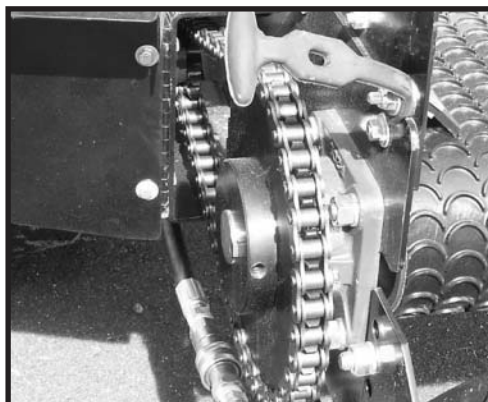

Figure 19-2

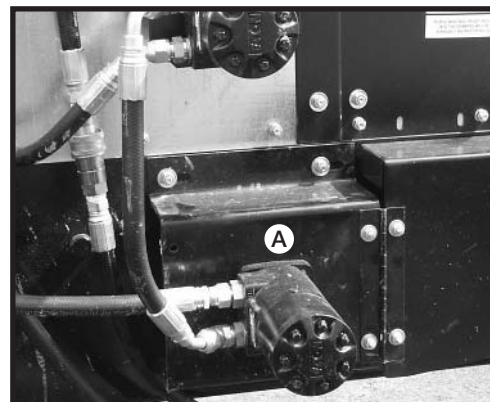

Figure 19-3

<b>Problem</b>	<b>Possible Cause</b>	<b>Correction</b>
Machine is engaged but spreader is not functioning	Material has jammed agitator	Disengage machine, raise end gate & remove foreign material
	Material has jammed spinners/beaters	Disengage machine from power source and remove foreign material
	Tractor hydraulic oil level might be too low	Fill oil reservoir to proper level
Spinners/beaters are turning, but material is not feeding	Belt is slipping or has broken	See belt maintenance section to replace or repair
	Belt drive chain has broken or jumped off sprocket	See chain maintenance section
Belts and spinners/beaters are rotating in reverse	Tractor hydraulic supply lines are reversed	Reverse lines on spreader
Hydraulic system doesn't have enough power to operate	Pump seals are worn; obstruction in hydraulic lines, etc.	See hydraulic maintenance section
	Oil overheated	
	Tractor hydraulic oil level might be too low	Fill oil reservoir to proper level
Spinner attachment does not spread evenly: Spreads more to the outside and not enough in center		Move spinner attachment back 1 hole to attain desired spread
Spinner attachment does not spread evenly: Spreads more in the center not enough outside		Move spinner attachment forward 1 hole to attain desired spread



**Loads**

<b>ADJUSTMENTS</b>	
Spread Adjustments	12
Metering Gate Adjustment	12
Web Speed	12
Attachment Adjustments	12
Brush	12
Delivery Beater	12
Conveyor	13
Spinners	14
Additional Adjustment	14
Optional Agitator Beater	14
<b>BEFORE USE</b>	4
<b>CAUTION</b>	3
<b>DELIVERY REPORT</b>	24
<b>GENERAL INFORMATION</b>	
Tractor Hitch	5
Tractor Size	5
<b>LUBRICATION</b>	15, 16
<b>MAINTENANCE</b>	
General	17
PTO Models	17
Delivery Beater	17
Wheel/Tire	17
Hydraulic System	17
Tractor Hydraulic	17
PTO Hydraulic	18
Wheel Bearing	18
Drive System (Floor Apron Belt)	19
Tension	19
Belt Tracking	19
Model 255	19
Maintenance Record	22
<b>OPERATION</b>	
Attaching to the Tractor	6
PTO Models	6
Tractor Hydraulic Models	7
Unhitching	7
Loading	7
Transporting	8
Operation Overview	9
Drive Styles	9
Ground Speed	9
Spreading	10, 11
PTO Models	11
Tractor Hydraulics	11
On Board Hydraulics	11
<b>SAFETY DECALS</b>	2
<b>SPECIFICATIONS</b>	1
<b>TO THE OWNER</b>	(inside cover)
<b>TROUBLESHOOTING</b>	20
<b>WARRANTY</b>	25

# DELIVERY REPORT

## SuperSpread™



Owner's Name \_\_\_\_\_

Owner's Address \_\_\_\_\_

Dealer's Name \_\_\_\_\_

Dealer's Address \_\_\_\_\_

Machine \_\_\_\_\_

Model \_\_\_\_\_

Serial # \_\_\_\_\_

Optional equipment installed or delivered with unit.

Inst.            Del.            Inst.            Del.

The Operator's Manual has been given to the owner and used to instruct him on these items checked below.

Dealer Representative's Signature \_\_\_\_\_

Delivery Date \_\_\_\_\_

- Safety Precautions
- Tractor Hitching
- Operation of Controls
- Field Operation
- Lubrication
- Machine Adjustments
- Maintenance Schedule
- Use of Optional Equipment
- Troubleshooting
- Non-Use Storage

"I have been instructed in the safety precautions, operation, care and maintenance of this machine as detailed in the Operator's Manual."

Owner's Signature \_\_\_\_\_

Date \_\_\_\_\_

## **Pequea's Limited Warranty**

Pequea Machine Company warrants to the original Purchaser all Machinery, Equipment, or Trailers manufactured by it, to be free from defects in material and workmanship under normal use and service. Its obligation under this Warranty shall be limited to replacement or repair of any parts thereof, free of charge to the original Purchaser, at its place of business, provided, however, that the part(s) to be replaced or repaired, shall within one (1) year after delivery to the original Purchaser, be demonstrated to be defective; which determination shall be made by the Company. The said components or parts must be returned through the Selling dealer or distributor directly to the Company with all transportation charges prepaid. Notice of defect shall be furnished in writing to the Seller and to the agent through whom the machinery was received, disclosing in full all known defects and failure in operation and use, and reasonable time shall be given to the Seller to remedy any such defects and failures. Failure to make such trial or give such notice shall be deemed an absolute acceptance by the Buyer and satisfaction in full of this Limited Warranty.

This Warranty does not cover, under any circumstances, any parts, components, or materials which, in the opinion of the Seller and Company, have been subjected to neglect, misuse, alteration, accident, or if repaired, with parts other than those manufactured by and obtained from Pequea Machine Company.

This Warranty does not cover components which are already covered by a separate Warranty provided by the supplier of said parts or components.

The Company's obligation under this Warranty is limited to repair or replacement, free of charge to the original Purchaser, of any part which in judgement of the Company is defective. This Warranty does not cover normal wear and tear.

**THIS WARRANTY IS MADE EXPRESSLY IN LIEU OF ALL OTHER WARRANTIES, EXPRESSED OR IMPLIED, INCLUDING ANY WARRANTY OF MERCHANTABILITY AND FITNESS FOR USE AND PURPOSE AND OF ALL OTHER OBLIGATIONS OR LIABILITIES ON ITS PART AND ANY IMPLIED WARRANTY. AND IT NEITHER ASSUMES NOR AUTHORIZES ANY OTHER LIABILITY IN CONNECTION WITH A SALE OF THIS MACHINE. THIS WARRANTY SHALL NOT APPLY TO THIS MACHINE OR TO ANY PART THEREOF WHICH HAS BEEN SUBJECT TO ACCIDENT, NEGLIGENCE, ALTERATION, ABUSE, OR MISUSE.**

The Company makes no Warranty whatsoever in respect to accessories or parts not supplied by the Company. The term "original Purchaser" as used in this warranty, shall be deemed that person for whom the Machine, Equipment, or Trailer is originally supplied. This Warranty shall apply only within the boundaries of the continental United States.

Under this Warranty, the Company cannot guarantee that existing conditions beyond its control will not affect its ability to obtain materials or manufacture necessary replacement parts.

No one is authorized to alter, modify, or change the terms of this Warranty in any manner.

The Company warrants the Construction of the equipment sold herein and will replace at its expense for a period of (1) year from the date hereof, any parts which prove defective as determined under the terms of this Limited Warranty.



A Skibo Company • 200 Jalyn Dr. • P.O. Box 399 • New Holland, PA 17557  
717/354-4343 • fax: 717/354-8843 • email: [pequea@frontiernet.net](mailto:pequea@frontiernet.net)  
[www.pequeemachine.com](http://www.pequeemachine.com)