

HYDRAULICALLY CLAMPS AND LIFT CONTAINERS

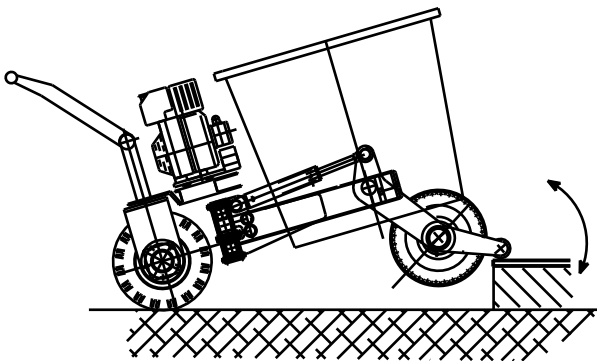

THE MACHINE IS ABLE TO MOUNT STEPS OF MORE THAN 8" HEIGHT

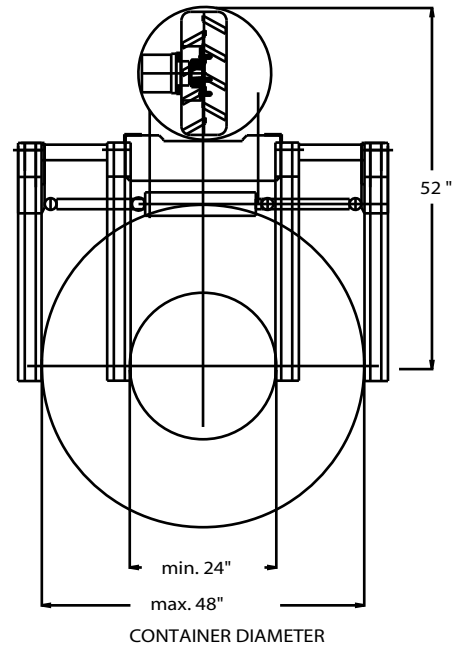

PZ 1200 motorized container mover

Engine:	Single Cylinder 5hp Honda Gas Engine recoil starter
Optional:	hydraulic steering
Container diameter:	24 - 48 inch
Tires:	2 x front tires 4.00/8" 10 ply max. load each front tire 2200lbs 1 x back tire 18 x 9.50/8"



PAZZAGLIA S.p.A.

IMPORTER FOR NORTH AMERICA:
AUTRUSA ENTERPRISES
941 Perkiomenville Rd.
Perkiomenville, PA 18074 USA

ph. 610-754-1110
fax 610-754-1112
email: sales@autrusa.com
website: www.autrusa.com